



UNIVERSITY OF CAMBRIDGE INTERNATIONAL EXAMINATIONS
International General Certificate of Secondary Education

CANDIDATE
NAME

--

CENTRE
NUMBER

--	--	--	--	--

CANDIDATE
NUMBER

--	--	--	--



MATHEMATICS

0580/42

Paper 4 (Extended)

May/June 2013

2 hours 30 minutes

Candidates answer on the Question Paper.

Additional Materials: Electronic calculator
 Tracing paper (optional)

Geometrical instruments

READ THESE INSTRUCTIONS FIRST

Write your Centre number, candidate number and name on all the work you hand in.

Write in dark blue or black pen.

You may use a pencil for any diagrams or graphs.

Do not use staples, paper clips, highlighters, glue or correction fluid.

DO NOT WRITE IN ANY BARCODES.

Answer **all** questions.

If working is needed for any question it must be shown below that question.

Electronic calculators should be used.

If the degree of accuracy is not specified in the question, and if the answer is not exact, give the answer to three significant figures. Give answers in degrees to one decimal place.

For π , use either your calculator value or 3.142.

At the end of the examination, fasten all your work securely together.

The number of marks is given in brackets [] at the end of each question or part question.

The total of the marks for this paper is 130.

This document consists of **19** printed pages and **1** blank page.



1 A tennis club has 560 members.

(a) The ratio men : women : children = 5 : 6 : 3.

(i) Show that the club has 240 women members.

Answer(a)(i)

[2]

(ii) How many members are children?

Answer(a)(ii) [1]

(b) $\frac{5}{8}$ of the 240 women members play in a tournament.

How many women members do **not** play in the tournament?

Answer(b) [2]

(c) The annual membership fee in 2013 is \$198 for each adult and \$75 for each child.

(i) Calculate the total amount the 560 members pay in 2013.

Answer(c)(i) \$ [2]

(ii) The adult fee of \$198 in 2013 is 5.6% more than the fee in 2012.

Calculate the adult fee in 2012.

Answer(c)(ii) \$ [3]

(d) The club buys 36 tennis balls for \$9.50 and sells them to members for \$0.75 each.

Calculate the percentage profit the club makes.

Answer(d) % [3]

(e) A tennis court is a rectangle with length 23.7 m and width 10.9 m, each correct to 1 decimal place.

Calculate the upper and lower bounds of the perimeter of the court.

Answer(e) Upper bound m

Lower bound m [3]

2 (a)

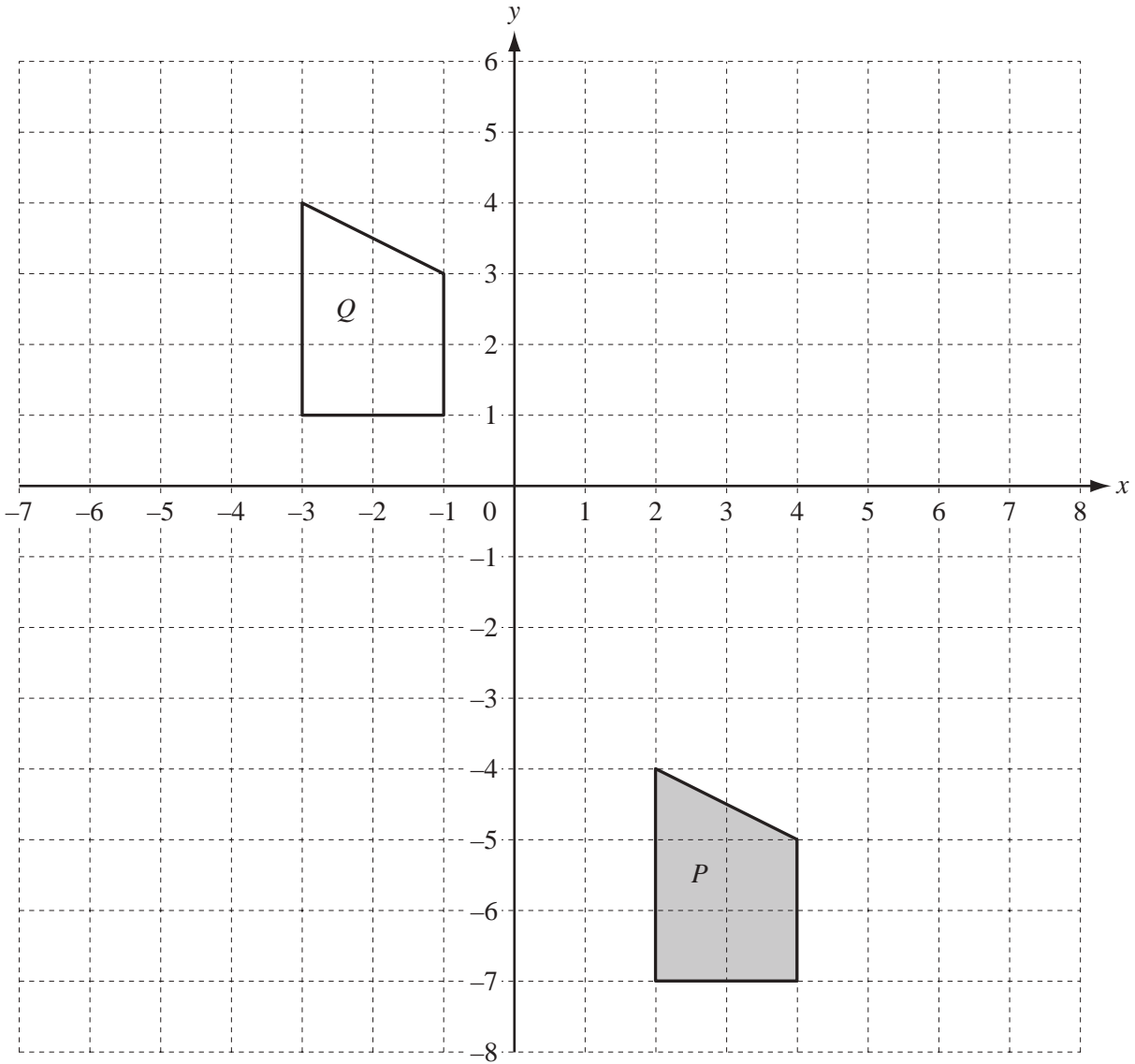

(i) Describe fully the **single** transformation which maps shape *P* onto shape *Q*.

Answer(a)(i) [2]

(ii) On the grid above, draw the image of shape *P* after reflection in the line $y = -1$. [2]

(iii) On the grid above, draw the image of shape *P* under the transformation represented by the matrix $\begin{pmatrix} 0 & -1 \\ 1 & 0 \end{pmatrix}$. [3]

(b)

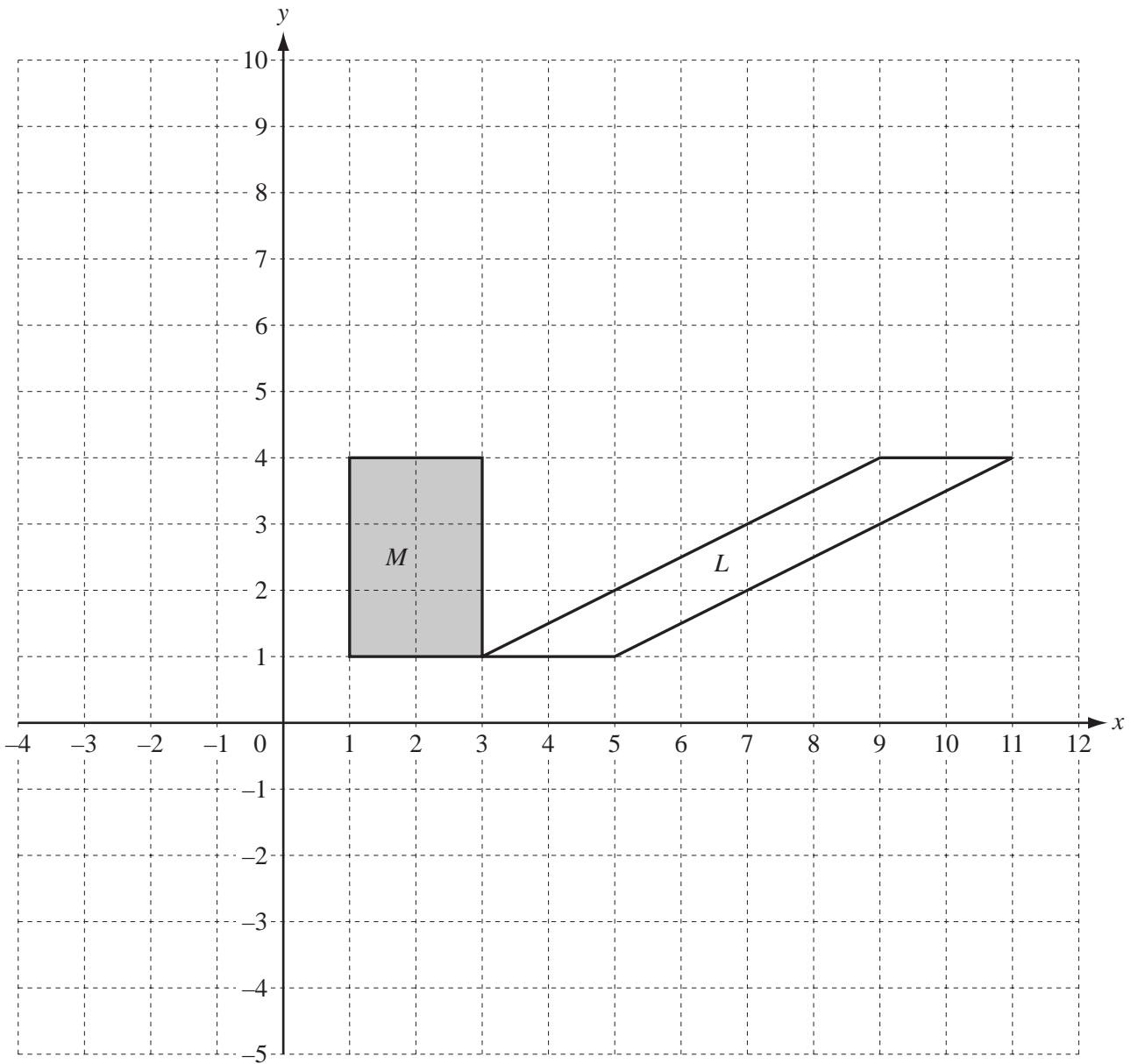

(i) Describe fully the **single** transformation which maps shape *M* onto shape *L*.

Answer(b)(i) [3]

(ii) On the grid above, draw the image of shape *M* after enlargement by scale factor 2, centre (5, 0). [2]

- 3 The table shows some values for the function $y = 11x - 2x^2 - 12$ for $1 \leq x \leq 4.5$.

x	1	1.5	2	2.5	3	3.5	4	4.5
y	-3		2	3	3			

- (a) Complete the table of values.

[3]

- (b) On the grid below, draw the graph of $y = 11x - 2x^2 - 12$ for $1 \leq x \leq 4.5$.

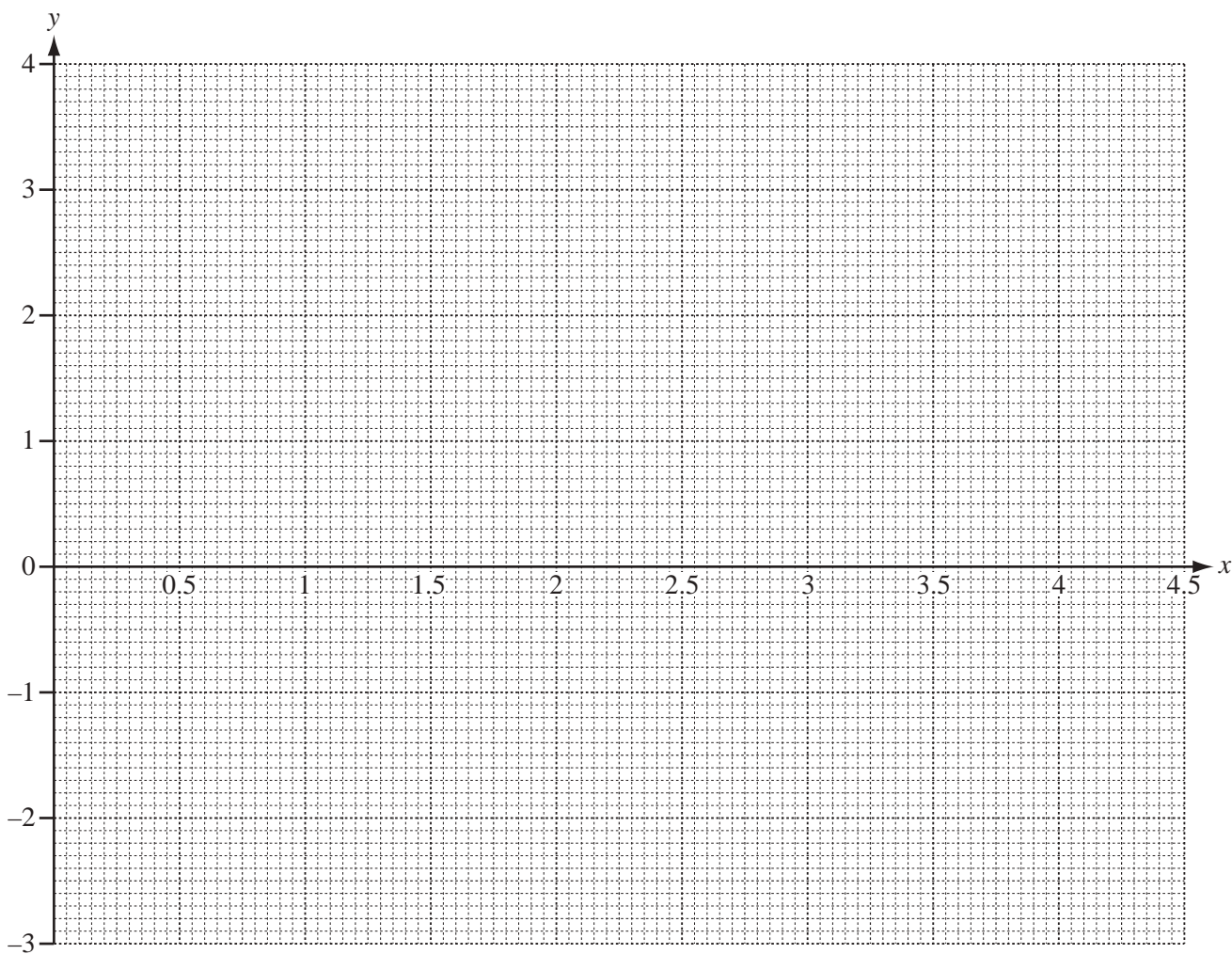

[4]

For
Examiner's
Use

- (c) By drawing a suitable line, use your graph to solve the equation $11x - 2x^2 = 11$.

Answer(c) $x = \dots\dots\dots$ or $x = \dots\dots\dots$ [2]

- (d) The line $y = mx + 2$ is a tangent to the curve $y = 11x - 2x^2 - 12$ at the point P .

By drawing this tangent,

- (i) find the co-ordinates of the point P ,

Answer(d)(i) ($\dots\dots\dots$, $\dots\dots\dots$) [2]

- (ii) work out the value of m .

Answer(d)(ii) $m = \dots\dots\dots$ [2]

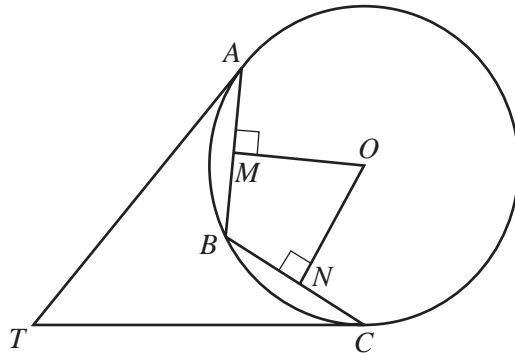

NOT TO
SCALE

A, B and C lie on the circle centre O , radius 8.5 cm.
 $AB = BC = 10.7$ cm.
 OM is perpendicular to AB and ON is perpendicular to BC .

- (a) Calculate the area of the circle.

Answer(a) cm² [2]

- (b) Write down the length of MB .

Answer(b) cm [1]

- (c) Calculate angle MOB and show that it rounds to 39° correct to the nearest degree.

Answer(c)

[2]

- (d) Using angle $MOB = 39^\circ$, calculate the length of the **major** arc AC .

Answer(d) cm [3]

- (e) The tangents to the circle at A and at C meet at T .

Explain clearly why triangle ATB is congruent to triangle CTB .

Answer(e)

[3]

5 Paul buys a number of large sacks of fertiliser costing $\$x$ each.

He spends $\$27$.

(a) Write down, in terms of x , an expression for the number of large sacks which Paul buys.

Answer(a) [1]

(b) Rula buys a number of small sacks of fertiliser.
Each small sack costs $\$2$ less than a large sack.
Rula spends $\$25$.

Write down, in terms of x , an expression for the number of small sacks which Rula buys.

Answer(b) [1]

(c) Rula buys 4 more sacks than Paul.

Write down an equation in x and show that it simplifies to $2x^2 - 3x - 27 = 0$.

Answer(c)

[4]

(d) Solve $2x^2 - 3x - 27 = 0$.

Answer(d) $x = \dots\dots\dots$ or $x = \dots\dots\dots$ [3]

(e) Calculate the number of sacks which Paul buys.

Answer(e) [1]

6 (a)

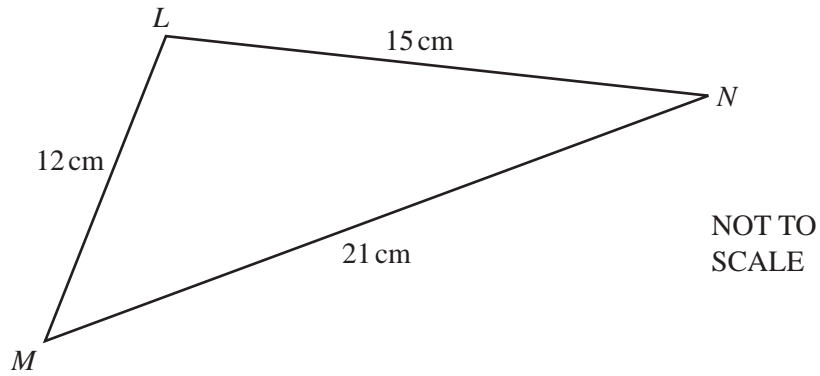

The diagram shows triangle LMN with $LM = 12$ cm, $LN = 15$ cm and $MN = 21$ cm.

- (i) Calculate angle LMN .
Show that this rounds to 44.4° , correct to 1 decimal place.

Answer(a)(i)

[4]

- (ii) Calculate the area of triangle LMN .

Answer(a)(ii) cm^2 [2]

(b)

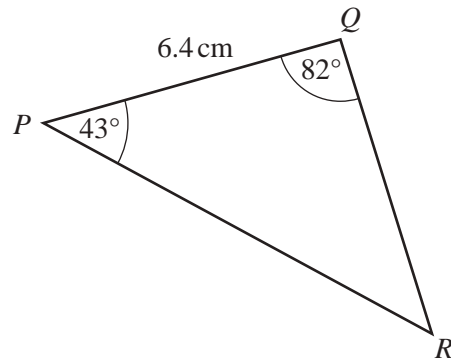
NOT TO
SCALEFor
Examiner's
Use

The diagram shows triangle PQR with $PQ = 6.4$ cm, angle $PQR = 82^\circ$ and angle $QPR = 43^\circ$.

Calculate the length of PR .

Answer(b) $PR = \dots\dots\dots$ cm [4]

$$7 \quad \mathbf{A} = \begin{pmatrix} 5 \\ 7 \end{pmatrix} \quad \mathbf{B} = (6 \quad -4) \quad \mathbf{C} = \begin{pmatrix} 2 & 4 \\ 1 & 3 \end{pmatrix} \quad \mathbf{D} = \begin{pmatrix} 2 & 9 \\ -1 & -3 \end{pmatrix}$$

(a) Calculate the result of each of the following, if possible.

If a calculation is not possible, write “not possible” in the answer space.

(i) $3\mathbf{A}$

Answer(a)(i) [1]

(ii) \mathbf{AC}

Answer(a)(ii) [1]

(iii) \mathbf{BA}

Answer(a)(iii) [2]

(iv) $\mathbf{C} + \mathbf{D}$

Answer(a)(iv) [1]

(v) \mathbf{D}^2

Answer(a)(v) [2]

(b) Calculate \mathbf{C}^{-1} , the inverse of \mathbf{C} .

Answer(b) [2]

8 In this question, give all your answers as fractions.

When Ivan goes to school in winter, the probability that he wears a hat is $\frac{5}{8}$.

If he wears a hat, the probability that he wears a scarf is $\frac{2}{3}$.

If he does not wear a hat, the probability that he wears a scarf is $\frac{1}{6}$.

(a) Complete the tree diagram.

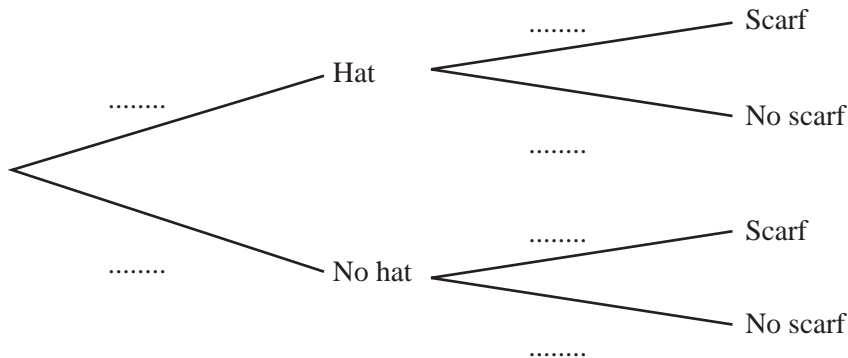

[3]

(b) Find the probability that Ivan

(i) does not wear a hat and does not wear a scarf,

Answer(b)(i) [2]

(ii) wears a hat but does not wear a scarf,

Answer(b)(ii) [2]

(iii) wears a hat or a scarf but not both.

Answer(b)(iii) [2]

(c) If Ivan wears a hat and a scarf, the probability that he wears gloves is $\frac{7}{10}$.

Calculate the probability that Ivan does **not** wear all three of hat, scarf and gloves.

Answer(c) [3]

9 (a)

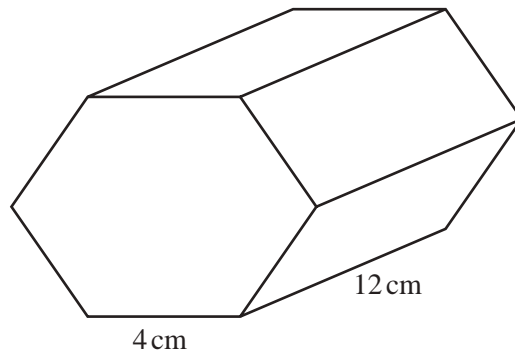
NOT TO
SCALEFor
Examiner's
Use

The diagram shows a prism of length 12 cm.
The cross section is a regular hexagon of side 4 cm.

Calculate the total surface area of the prism.

Answer(a) cm² [4]

(b) Water flows through a cylindrical pipe of radius 0.74 cm.
It fills a 12 litre bucket in 4 minutes.

(i) Calculate the speed of the water through the pipe in centimetres per minute.

Answer(b)(i) cm/min [4]

- (ii) When the 12 litre bucket is emptied into a circular pool, the water level rises by 5 millimetres.

Calculate the radius of the pool correct to the nearest centimetre.

*For
Examiner's
Use*

Answer(b)(ii) cm [5]

10 (a) Write as a single fraction

(i) $\frac{5}{4} - \frac{2x}{5}$,

Answer(a)(i) [2]

(ii) $\frac{4}{x+3} + \frac{2x-1}{3}$.

Answer(a)(ii) [3]

(b) Solve the simultaneous equations.

$$9x - 2y = 12$$

$$3x + 4y = -10$$

Answer(b) $x =$

$y =$ [3]

(c) Simplify $\frac{7x + 21}{2x^2 + 9x + 9}$.

*For
Examiner's
Use*

Answer(c) [4]

- 11 Sidney draws the triangle OP_1P_2 .
 $OP_1 = 3$ cm and $P_1P_2 = 1$ cm.
 Angle $OP_1P_2 = 90^\circ$.

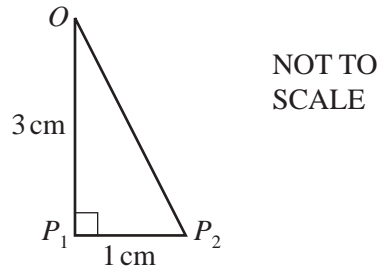

- (a) Show that $OP_2 = \sqrt{10}$ cm.

Answer(a)

[1]

- (b) Sidney now draws the lines P_2P_3 and OP_3 .
 Triangle OP_2P_3 is mathematically similar
 to triangle OP_1P_2 .

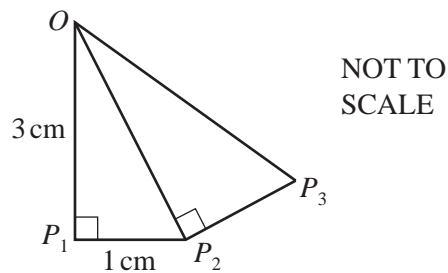

- (i) Write down the length of P_2P_3 in the form $\frac{\sqrt{a}}{b}$ where a and b are integers.

Answer(b)(i) $P_2P_3 = \dots\dots\dots$ cm [1]

- (ii) Calculate the length of OP_3 giving your answer in the form $\frac{c}{d}$ where c and d are integers.

Answer(b)(ii) $OP_3 = \dots\dots\dots$ cm [2]

- (c) Sidney continues to add
 mathematically similar triangles
 to his drawing.

Find the length of OP_5 .

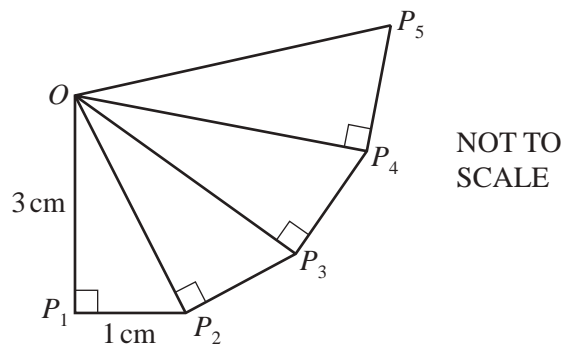

Answer(c) $OP_5 = \dots\dots\dots$ cm [2]

- (d) (i) Show that angle $P_1OP_2 = 18.4^\circ$, correct to 1 decimal place.

Answer(d)(i)

[2]

- (ii) Write down the size of angle P_2OP_3 .

Answer(d)(ii) Angle $P_2OP_3 = \dots\dots\dots$ [1]

- (iii) The last triangle Sidney can draw without covering his first triangle is triangle $OP_{(n-1)}P_n$.

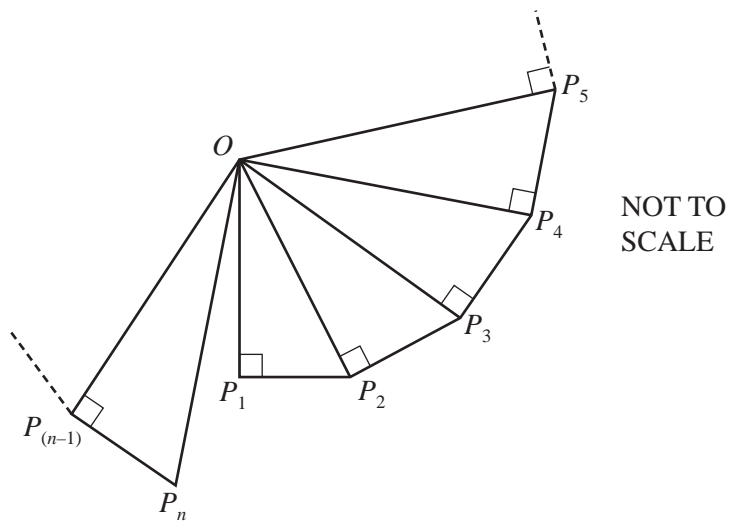

Calculate the value of n .

Answer(d)(iii) $n = \dots\dots\dots$ [3]

BLANK PAGE

Permission to reproduce items where third-party owned material protected by copyright is included has been sought and cleared where possible. Every reasonable effort has been made by the publisher (UCLES) to trace copyright holders, but if any items requiring clearance have unwittingly been included the publisher will be pleased to make amends at the earliest possible opportunity.

University of Cambridge International Examinations is part of the Cambridge Assessment Group. Cambridge Assessment is the brand name of University of Cambridge Local Examinations Syndicate (UCLES), which is itself a department of the University of Cambridge.